

SR598



Mounting Pattern
200 x 200 up to
900 x 600mm



Max Load
300lb (136.1kg)
display

TECH&LEARNING **WINNER**
BEST of SHOW
InfoComm 2015

- Integrated cable management protects, contains and conceals cables for a clean, professional installation
- Pre-assembled base provides rigidity, stability and quick assembly
- Textured black powder coat finish helps hide finger prints and dust
- Optional ACC-MS component shelf can be positioned anywhere along either column by simply lifting and repositioning
- Universal mount fits displays with mounting patterns from 200 x 200mm up to 900 x 600mm
- Cart includes (4) plastic base pads for instances when casters are not needed

SMARTMOUNT[®] Flat Panel Cart

FOR 55" TO 98" DISPLAYS

The SR598 SmartMount[®] Flat Panel Cart has been redesigned to include all of the features you may need, making it perfect for any application. Mobility, appealing design, display height adjustment and a pre-assembled base ensure quick assembly, while providing a rigid, but attractive structure that fits into any décor. The 4" casters make it easy to move from room to room, while the UL[®] certification ensures that it can be done safely.



✉ info@peerless-av.com
🌐 peerless-av.com

peerless-AV[®]
Driving Technology Through Innovation

SR598	SmartMount® Flat Panel Cart for 55" to 98" Displays
--------------	---

Product Specifications

	DIMENSIONS (W X H X D)	PRODUCT WEIGHT	LOAD CAPACITY	FINISH	AVAILABLE COLORS
SR598	46.01" x 68.38" x 29.00" (1169 x 1736 x 737mm)	89lb (40.5kg)	300lb (136.1kg) display	Textured Powder Coat	Black

Package Specifications

	PACKAGE SIZE (W x H x D)	PACKAGE SHIP WEIGHT	PACKAGE UPC CODE	PACKAGE CONTENTS	UNITS IN PACKAGE
SR598	47.50" x 12.50" x 38.50" (1207 x 318 x 978mm)	109lb (49.5kg)	735029304975	Assembled Base, (2) Aluminum Columns, Universal Display Adaptor, (2) Swivel Casters, (2) Locking Swivel Casters, (4) Plastic Base Pads, Hardware & Instructions	1

Accessories

- | | |
|---|---|
| ACC310: Leveling Feet Accessory | ACC-LA: Laptop Arm |
| ACC316: Safety Belt | ACC-UCM: Universal AV Component Mount |
| ACC320: Electrical Outlet Strip with Cord Wrap | ACC-MS: Metal Shelf |
| ACC-BPR: Bumper Accessory for legs | ACC-VCS: Video Conferencing Camera Shelf |

All dimensions = inch (mm)

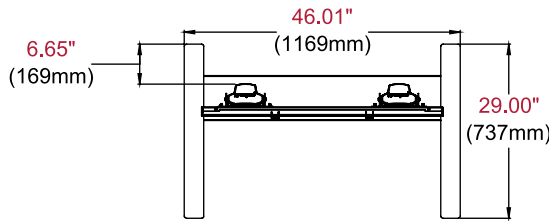

TOP VIEW

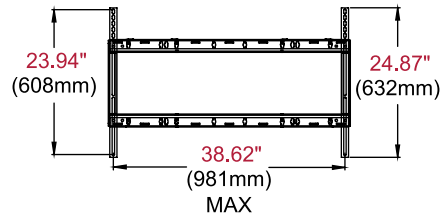

ADAPTOR BRACKET

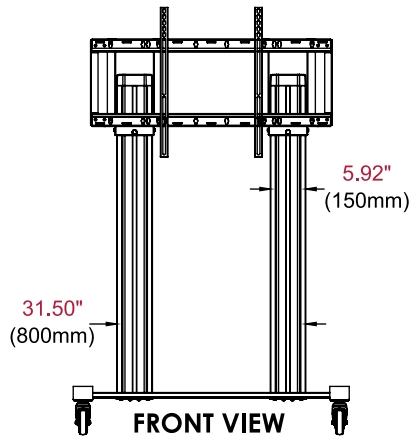

FRONT VIEW

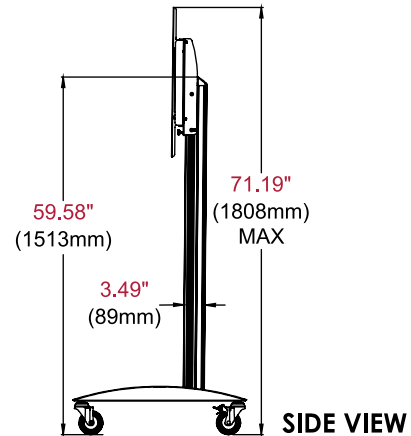

SIDE VIEW

Architect Specifications

The SmartMount® Flat Panel Cart shall be a Peerless-AV model SR598 and shall be located where indicated on the plans. Assembly and installation shall be done according to instructions provided by the manufacturer.

Visit peerless-av.com to see the complete line of AV solutions from Peerless-AV, including outdoor displays, wireless, kiosks, digital audio, display mounts, projector mounts, carts/stands, and a full assortment of accessories.

Peerless-AV
2300 White Oak Circle
Aurora, IL 60502 USA
(800) 865-2112
(630) 375-5100
Fax: (800) 359-6500

Peerless-AV EMEA
Unit 3 Watford Interchange
Colonial Way, Watford
Herts, WD24 4WP
United Kingdom
+44 (0) 1923 200100
Fax: +44 (0) 1923 200101

Peerless-AV Latin America
Av. de las Industrias 413
Parque Industrial Escobedo
General Escobedo, N.L.,
México, 66062
+52 (81) 8384-8300
Fax: +52 (81) 8384-8360

